



Aftec is a leading manufacturer of cable glands, Cable Connectors and associated accessories, used extensively for power control, lighting and instrumentation cable application in connection with IEC and NEC Cables.

Having the widest range of cable glands products to meet every kind of requirement for use in marine, Industrial and Non(Industrial)Areas.





CABLE GLAND AND CLEATS SELECTOR CHART FOR

PVC/ SWA/PVC & XLPE/ SWA/ PVC 600/ 1000 VOLT POWER CABLES

CONDUCTOR AREA	NO OF CORES	BW INDOOR GLANDS	CW OUTDOOR GLANDS	E1 W DOUBLE COMPRESSION GLANDS	SINGLE BOLT CLEAT	DOUBLE BOLT CLEAT
1.5	2	20S	20S	20S	ASBC-AA	-
	3	20S	20S	20S	ASBC-AA	-
	4	20S	20S	20S	ASBC-AB	-
	7	20S	20S	20S	ASBC-AC	-
	12	25	25	25	ASBC-AD	-
	19	25	25	25	ASBC-AE	-
	27	32	32	32	ASBC-AF	-
	37	32	32	32	ASBC-AF	-
2.5	2	20S	20S	20S	ASBC-AB	-
	3	20S	20S	20S	ASBC-AB	-
	4	20S	20S	20S	ASBC-AB	-
	7	20	20	20	ASBC-AC	-
	12	25	25	25	ASBC-AD	-
	19	32	32	32	ASBC-AE	-
	27	32	32	32	ASBC-AF	-
	37	40	40	40	ASBC-AG	-
4	2	20S	20S	20S	ASBC-AB	-
	3	20S	20S	20S	ASBC-AB	-
	4	20	20	20	ASBC-AC	-
	7	25	25	25	ASBC-AD	-
	12	25	25	25	ASBC-AE	-
	19	32	32	32	ASBC-AF	-
	27	40	40	40	ASBC-AG	-
	37	40	40	40	ASBC-AH	-
6	2	20S	20S	20S	ASBC-AB	-
	3	20	20	20	ASBC-AC	-
	4	20	20	25	ASBC-AD	-
10	2	20	20	20	ASBC-AC	-
	3	25	25	25	ASBC-AD	-
	4	25	25	25	ASBC-AD	-
16	2	25	25	25	ASBC-AD	-
	3	25	25	25	ASBC-AD	-
	4	25	25	25	ASBC-AE	-
25	2	25	25	25	ASBC-AE	-
	3	32	32	32	ASBC-AE	-
	4	32	32	32	ASBC-AF	-

CABLE GLAND AND CLEATS SELECTOR CHART FOR						
PVC/ SWA/PVC & XLPE/ SWA/ PVC 600/ 1000 VOLT POWER CABLES						
CONDUCTOR AREA	NO OF CORES	BW INDOOR GLANDS	CW OUTDOOR GLANDS	E1 W DOUBLE COMPRESION GLANDS	SINGLE BOLT CLEAT	DOUBLE BOLT CLEAT
mm ²						
35	2	32	32	32	ASBC-AF	-
	3	32	32	32	ASBC-AF	-
	4	32	32	32	ASBC-AF	-
50	2	25	25	25	ASBC-AE	-
	3	32	32	32	ASBC-AF	-
	4	32	32	32	ASBC-AF	-
70	2	32	32	32	ASBC-AF	-
	3	32	32	32	ASBC-AF	-
	4	40	40	40	ASBC-AG	-
95	2	32	32	32	ASBC-AG	-
	3	40	40	40	ASBC-AG	-
	4	50S	50S	50S	ASBC-AH	-
120	2	40	40	40	ASBC-AG	-
	3	40	40	40	ASBC-AG	-
	4	50S	50	50	ASBC-AH	-
150	2	40	40	40	ASBC-AG	-
	3	50S	50S	50S	ASBC-AH	-
	4	50	50	50	-	ATBC-AA
185	2	50S	50S	50S	ASBC-AH	-
	3	50	50	50	ASBC-AH	-
	4	63S	63S	63S	-	ATBC-AA
240	2	50	50	50	ASBC-AH	-
	3	63S	63S	63S	-	ATBC-AA
	4	63	63	63	-	ATBC-AC
300	2	50	63S	63S	-	ATBC-AA
	3	63S	63	63	-	ATBC-AB
	4	75S	75S	75S	-	ATBC-AD
400	2	63S	63S	63S	-	ATBC-AB
	3	63	63	63	-	ATBC-AC
	4	75	75	75	-	ATBC-AE
630	2	50S	50S	50S	ASBC-AH	-
	1	50	50	50	-	ATBC-AA

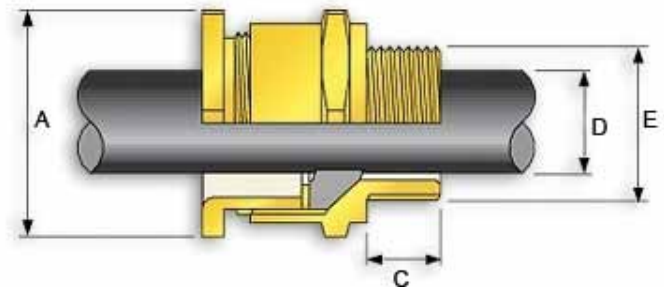

A2 UNARMOUR GLANDS

Aftec A2 brass industrial cable glands can be used for unarmoured cables for Indoor & Outdoor applications. It provides a weather proof, seal on outer insulation.

Technical Data

Standard

: Designed to BS 6121 Part 1:1987 EN 50262: 1999.

Ingress Protection

: IP 66, IP 67, IP 68

Operating Temperature

: -60°C to + 150°C

Material Available

: Brass, Brass NP, Stainless Steel, Aluminum

MODEL NO.	METRIC ENTRY THREAD	MINIMUM THREAD LENGTH	CABLE DIA MAX		MAX ACROSS CORNERS DIA	PVC SHROUD
			D			
	E	C	MIN	MAX	A	
A2 20/16	20	15	3.1	8.6	26	A20/16
A2 20S	20	15	6.1	11.6	26	A20S
A2 20	20	15	6.5	13.9	30	A20
A2 25S	25	15	8.8	17.0	39.5	A25S
A2 25	25	15	11.1	19.9	39.5	A25
A2 32	32	15	17.0	26.2	45	A32
A2 40	40	15	22.0	32.1	53.5	A40
A2 50S	50	15	29.5	38.1	66	A50S
A2 50	50	15	35.6	44.0	66.25	A50
A2 63S	63	15	40.1	49.9	75	A63S
A2 63	63	15	47.2	55.9	81.5	A63
A2 75S	75	15	52.8	61.9	90	A75S
A2 75	75	15	59.1	67.9	98	A75
A2 90	90	21	66.6	79.3	115	A90

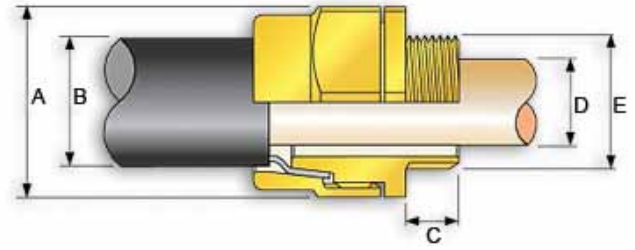

ABW ARMOUR GLANDS

Aftec BW brass industrial cable glands can be used for single wire armoured cables for Indoor applications. It provides earth continuity through armour wire termination.

Technical Data

Standard

: Designed to BS 6121 Part 1:2005 En 12168.

Material available

: Brass, Brass NP, Stainless Steel, Aluminum

MODEL NO.	METRIC ENTRY THREAD	MINIMUM THREAD LENGTH	CABLE DIA MAX		MAX ACROSS CORNERS DIA	ARMOUR WIRE DIA	PVC SHROUD
			D				
	E	C	MIN	MAX	A		
BW 20S	20	9.5	11.6	16.1	23.25	0.9/1.25	B20S
BW 20	20	9.5	13.9	21.1	27.35	0.9/1.25	B20
BW 25S	25	9.5	17.8	27.4	37.5	1.25/1.6	B25S
BW 25	25	9.5	19.9	27.4	37.5	1.25/1.6	B25
BW 32	32	9.5	61.9	76.2	45	1.6/2	B32
BW 40	40	14.5	61.9	76.2	54	1.6/2	B40
BW 50S	50	14.5	61.9	76.2	67.5	2/2.25	B50S
BW 50	50	14.5	61.9	76.2	71	2/2.5	B50
BW 63S	63	14.5	61.9	76.2	83	2.5	B63S
BW 63	63	14.5	61.9	76.2	86	2.5	B63
BW75S	75	14.5	61.9	76.2	99	2.5	B75S
BW75	75	14.5	61.9	82.9	106	2.5/3.15	B75

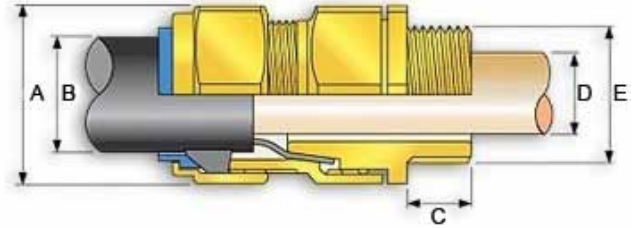

ACW ARMOUR GLANDS

Aftec CW brass single compression industrial cable glands can be used for single wire armoured cables for Indoor & Outdoor applications. It provides earth continuity through armour wire termination & a weather proof, seal on the outer insulation. Universal clamping ring on the armour clamp allows the disconnection of the equipment from the cable easily.

Technical Data

Standard	: Designed to BS 6121 Part 1:1987 EN 50262: 1999.
Ingress Protection	: IP 66, IP 67, IP 68
Operating Temperature	: -60°C to + 150°C
Material available	: Brass, Brass NP, Stainless Steel, Aluminum

MODEL NO.	METRIC ENTRY THREAD	MINIMUM THREAD LENGTH	CABLE DIA MAX	CABLE DIA B		MAX ACROSS CORNERS DIA	ARMOUR WIRE DIA	PVC SHROUD
	E	C	D	MIN	MAX	A		
CW 20/16	20	15	8.6	8.0	13.4	25	0.90	C20/16
CW 20S	20	9.5	11.6	11.4	15.9	26.8	0.9/1.25	C20S
CW 20	20	9.5	13.9	16.0	20.9	30.5	0.9/1.25	C20
CW 25S	25	9.5	17.8	22.0	27.4	40.8	1.25/1.6	C25S
CW 25	25	9.5	19.9	22.0	27.4	40.8	1.25/1.6	C25
CW 32	32	9.5	26.2	26.0	33.9	51	1.60/2.00	C32
CW 40	40	14.5	32.1	31.0	40.0	59	1.60/2.00	C40
CW 50S	50	14.5	38.1	36.0	46.7	67	2.00/2.50	C50S
CW 50	50	14.5	44.0	44.0	53.1	78.5	2.00/2.50	C50
CW 63S	63	14.5	50.0	48.9	59.4	84.5	2.50	C63S
CW 63	63	14.5	55.9	58.0	65.9	88.5	2.50	C63
CW 75S	75	14.5	61.9	60.6	72.1	98	2.50	C75S
CW 75	75	14.5	67.9	64.9	78.5	108	2.5/3.15	C75
CW 90	90	15	79.3	76.0	90.4	120	3.15	C90

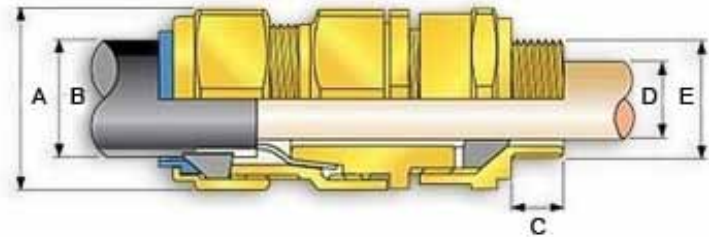

E1W ARMOUR GLANDS

Aftec E1W brass double compression industrial cable glands can be used for single wire armoured cables for Indoor & Outdoor applications. It provides earth continuity through armour wire termination & a weather proof, seal on the Inner & Outer insulation. Universal clamping ring on the armour clamp allows the disconnection of the equipment from the cable easily.

Technical Data

Standard

: Designed to BS 6121 Part 1:1987 EN 50262: 1999.

Ingress Protection

: IP 66, IP 67, IP 68

Operating Temperature

: -60°C to + 150°C

Material available

: Brass, Brass NP, Stainless Steel, Aluminum

MODEL NO.	METRIC ENTRY THREAD	MINIMUM THREAD LENGTH C	CABLE DIA		CABLE DIA		MAX ACROSS CORNERS DIA A	ARMOUR WIRE DIA	PVC SHROUD
	E		D		B				
			MIN	MAX	MIN	MAX			
E1W 20/16	20	15	3.1	8.6	8.0	13.4	26	0.90	E20/16
E1W 20S	20	15	6.1	11.6	11.4	15.9	26.8	0.9/1.25	E20S
E1W 20	20	15	6.5	13.9	16.0	20.9	30.5	0.9/1.25	E20
E1W 25S	25	15	8.8	17.8	22.0	27.4	40.8	1.25/1.6	E25S
E1W 25	25	15	11.1	19.9	22.0	27.4	40.8	1.25/1.6	E25
E1W 32	32	15	17.0	26.2	26.0	33.9	51	1.60/2.00	E32
E1W 40	40	15	22.0	32.1	31.0	40.0	59	1.60/2.00	E40
E1W 50S	50	15	29.5	38.1	36.0	46.7	67	2.00/2.50	E50S
E1W 50	50	15	35.6	44.0	44.0	53.1	78.5	2.00/2.50	E50
E1W 63S	63	15	40.1	49.9	48.9	59.4	84.5	2.50	E63S
E1W 63	63	15	47.2	55.9	58.0	65.9	88.5	2.50	E63
E1W 75S	75	15	52.8	61.9	60.6	72.1	98	2.50	E75S
E1W 75	75	15	59.1	67.9	64.9	78.5	108	2.5/3.15	E75
E1W 90	90	21	66.6	79.3	76.0	90.4	120	3.15	E90

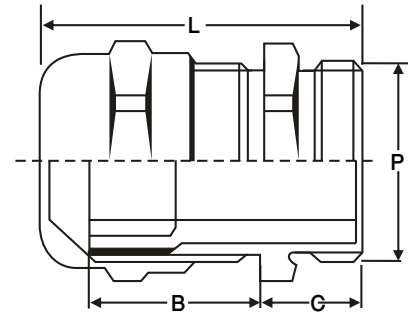

PG GLANDS BRASS NICKLE PLATED

Aftec PG Brass Nickel Plated Cable Glands Can be used for Unarmoured Cable for indoor and outdoor Application.

Technical Data

Standard

: Designed to BS 6121 Part 1:1987 EN 50262: 1999.

Ingress Protection

: IP 66, IP 67, IP 68

Operating Temperature

: -10° C to + 90° C

Material Available

: Brass Nickel Plated

MODEL NO.	PITCH	THREAD DIA	CABLE RANGE		B	C	LENGTH		QUANTITY
			MIN-MAX				MIN-MAX		
			A				L		
			MM				MM		
APG 7 NP	1.27	12.5	3.5-7		14	5	14-19		100
APG 9 NP	1.41	15.5	4-8		17	6	17-23		
APG 11 NP	1.41	19	4.5-10		20	6	20-25		
APG 13.5 NP	1.41	20.5	5-12		22	6.5	20-26		
APG 16 NP	1.41	22.5	7-13		24	6.5	20-27		
APG 21 NP	1.59	29	10-17		30	7	25-32		
APG 29 NP	1.59	37	18-25		39	8	33-40		
APG 36 NP	1.59	47	20-32		50	8	43-50		
APG 42 NP	1.59	54	28-38		57	9	50-57		
APG 48 NP	1.59	60	40-44		64	10	57-64		

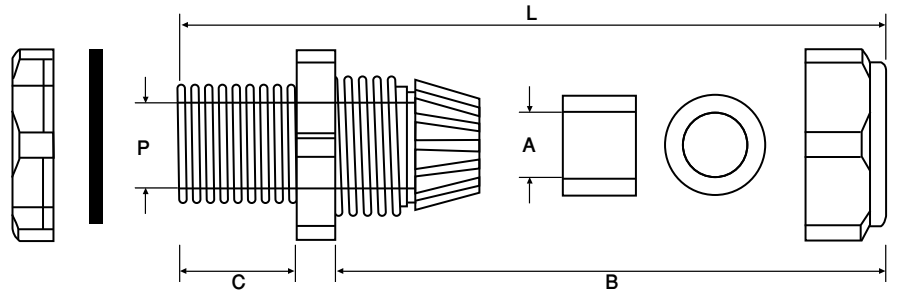

PG GLANDS

Aftec APG Polyamide glands can be used for circular unarmoured cables & wires for outdoor & indoor use.

Technical data

- Material** : Polyamide PA 6
- Operating Temperature** : -30°C to + 80°C
- Ingress Protection** : IP 54
- Color** : RAL 9000 White, RAL 9005 Black, RAL 7035 Grey.

MODEL NO.	PITCH	THREAD DIA	CABLE RANGE		B	C	LENGTH		QUANTITY
			MIN-MAX				MIN-MAX		
			A						
			MM					MM	
APG 7	1.27	12.5	3.5-7		15	8	18-22		
APG 9	1.41	15.5	5-8		19	8	22-26		
APG 11	1.41	19	5-10		22	8	23-28		
APG 13.5	1.41	20.5	7-12		24	9	24-29		
APG 16	1.41	22.5	10-14		27	10	26-31		
APG 21	1.59	29	13-18		33	12	30-35		
APG 29	1.59	37	18-25		42	12	33-39		
APG 36	1.59	47	20-32		53	14	42-49		
APG 42	1.59	54	28-38		60	14	42-50		
APG 48	1.59	60	40-44		65	15	42-50		

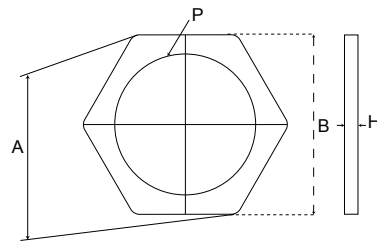

PG LOCKNUT

Secures a Gland in proper position, manufactured from polyamide

MODEL NO.	P	A	B	H	QUANTITY
		MM	MM	MM	
APG 7LN	7	21	19	5	100
APG 9LN	9	24	22	5	
APG 11LN	11	26	24	5	
APG 13.5LN	13.5	29	27	6	
APG 16LN	16	33	30	6	
APG 21LN	21	39	36	7	
APG 29LN	29	50	46	7	
APG 36LN	36	66	60	8	
APG 42LN	42	73	65	8	
APG 48LN	48	78	70	8	

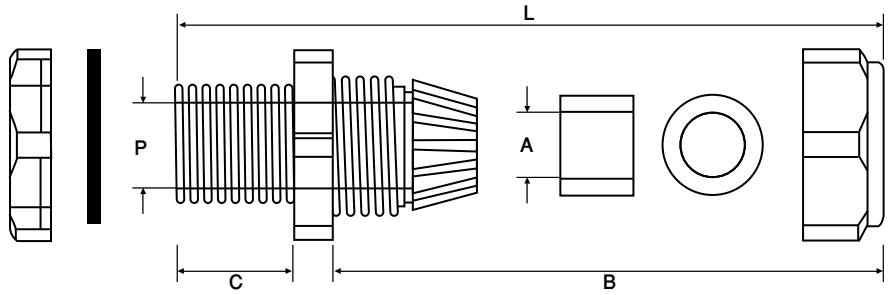

METRIC GLANDS

Aftec AMM Polyamide glands can be used for circular unarmoured cables & wires for outdoor & indoor use.

Technical data:

Material	: Polyamide PA 6
Operating Temperature	: -30°C to + 80°C
Ingress Protection	: IP 54
Color	: RAL 9005 Black

MODEL NO.	PITCH	THREAD DIA	CABLE RANGE		B	C	LENGTH	QUANTITY
			MIN-MAX				L	
			P	A				
			MM	MM				
AMM16	1.5	16.5	5-10		19	8	22-27	100
AMM20	1.5	20.5	7-13		25	9	24-30	
AMM25	1.5	25.5	10-17		30	10	28-39	
AMM32	1.5	32.5	13-21		36	10	33-44	
AMM40	1.5	40.5	19-28		46	10	36-45	
AMM50	1.5	50.5	27-35		55	12	43-52	
AMM63	1.5	63.5	34-45		66	12	45-55	

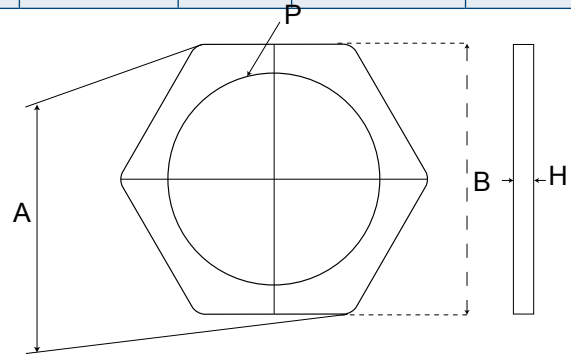

METRIC LOCKNUT

Secures a Gland in proper position, manufactured from polyamide

MODEL NO.	P	A	B	H	QUANTITY
		MM	MM	MM	
AMM16LN	M16	24	22	5	100
AMM20LN	M20	29	27	6	
AMM25LN	M25	35.5	32	6	
AMM32LN	M32	45	41	7	
AMM40LN	M40	55	50	7	
AMM50LN	M50	65	60	8	
AMM63LN	M63	82	75	8	



BRASS LOCK NUT

Secures a Cable Gland in proper position. Heavy duty hex lock is manufactured from brass.

MODEL NO.	A/F	THICKNESS
20MM	24.00	3.25
25MM	29.75	3.25
32MM	37.00	4.00
40MM	45.75	4.50
50MM	57.50	5.00
63MM	71.50	5.00
75MM	84.50	6.00



EARTH TAG

Provide earth continuity to the Cable Gland.

MODEL NO.	O.D	LENGTH
16MM	24.00	43.50
20MM	29.10	47.75
25MM	36.95	57.50
32MM	43.80	69.15
40MM	52.40	78.00
50MM	64.25	90.60
63MM	79.60	116.90
75MM	96.30	133.80



NYLON WASHER & FIBRE WASHER

To maintain proper ingress protection.

MODEL NO.	O.D	THICKNESS
20MM	24.00	1.5
25MM	29.75	
32MM	37.00	
40MM	45.75	
50MM	57.50	
63MM	71.50	
75MM	84.50	



SERRATED WASHER - SS316 L & SS304

To damper vibration of the cable gland, manufactured in stainless steel.

MODEL NO.	O.D	THICKNESS
20MM	24.00	1.5
25MM	29.75	
32MM	37.00	
40MM	45.75	
50MM	57.50	
63MM	71.50	
75MM	84.50	

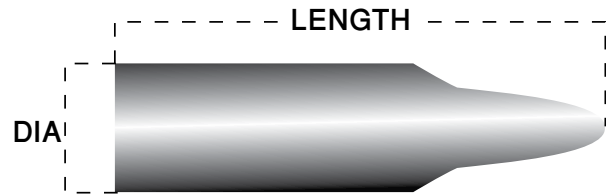

PVC SHROUD

To maintain additional environmental and corrosion protection.

MODEL NO	A2		BW		CW		E1W		ACW	
	DIA	LENGTH	DIA	LENGTH	DIA	LENGTH	DIA	LENGTH	DIA	LENGTH
20/16	26.0	80.0	20.5	80.0	27.0	94.5	27.0	102.0		
20S	26.0	80.0	23.5	82.0	27.0	94.5	27.0	102.0		
20	30.0	87.0	27.5	80.0	30.5	105.0	30.5	125.0		
25S	39.5	102.0	37.5	102.0	41.0	106.0	41.0	125.0		
25	39.5	102.0	37.5	102.0	41.0	106.0	41.0	125.0	42.0	106.0
32S					51.0	109.0				
32	45.0	103.0	45.0	98.0	51.0	109.0	51.0	125.0	52.0	109.0
40S					59.0	140.0				
40	53.5	98.0	54.0	103.0	59.0	140.0	59.0	160.0	62.0	140.0
50S	66.0	133.0	67.5	133.0	67.0	160.0	67.0	180.0	68.0	140.0
50	66.5	133.0	71.0	133.0	78.5	149.0	78.5	180.0	80.0	149.0
63S	75.0	150.0	83.0	152.0	84.5	180.0	84.5	200.0	84.0	180.0
63	81.5	152.0	86.0	152.0	88.5	180.0	88.5	200.0	92.0	180.0
75S	90.0	180.0	99.0	180.0	98.0	200.0	98.0	230.0		
75	98.0	180.0	106.0	180.0	108.0	225.0	108.0	255.0		
90	118.0	180.0	118.0	180.0	118.0	225.0				